



Outside Air Humidity & Temperature Sensor

RoHS

Model HU-227



- Ultra fast response cross-linked bulk polymer capacitive sensing element
- Proprietary hydrophobic and oleophobic ePTFE filter to protect the sensing element from condensation, fog, salt air, pollutants and other contaminants
- Conformal coated and moisture sealed electronics
- Rugged steel enclosure and thick-walled aluminum probe rated NEMA-4 (IP-65) to withstand weather extremes
- NIST traceable $\pm 2\%$ RH or $\pm 3\%$ RH calibration accuracy
- Two temperature compensated humidity output versions, 4-20 mA 2-wire or field selectable 0-5 VDC/0-10 VDC
- Conforms to EMC and RoHS standards

The HU-227 Outside Air Humidity and Temperature Sensor is designed to handle 100% condensing humidity. The electronics are moisture sealed with an acrylic coating, and the sensing element is protected with an ePTFE (expanded Teflon) filter media. The unit can be directly mounted inside fresh air hoods of air handlers or underneath roof overhangs of any building. The sensor can also be installed inside the air handler fresh air duct. The Teflon protected cross-linked capacitive humidity sensor is not affected by prolonged exposure to condensing humidity, harsh environments, contaminants, fog or other extreme environmental conditions. The rugged NEMA-4 (IP-65) rated steel enclosure, thick-walled aluminum probe and gasket sealed cover offer a reliable solution for factory-mounted applications. Each HU-227 is calibrated at multiple points in a NIST traceable calibration chamber to meet or exceed $\pm 2\%$ RH or $\pm 3\%$ RH accuracy. Units are temperature compensated over -30°F (-35°C) to $+130^{\circ}\text{F}$ (55°C) temperature range operation with negligible error. HU-227 is available with more than 16 types of interchangeable NTC thermistors, precision platinum, nickel or balco RTDs for universal compatibility.



HU-227

The HU-227 incorporates a cross-linked bulk polymer capacitive humidity sensor and precision NTC thermistor, platinum or balco RTD temperature sensor. Both temperature and humidity sensors are immune to most contaminants and at the same time provide a stable, repeatable, accurate humidity and temperature measurement with negligible hysteresis. The sensing elements are not affected by condensation. In fact, the probe may be immersed in distilled water without degrading the calibration accuracy. The HU-227 utilizes sophisticated integrated circuits to provide a high level, fully conditioned, and temperature compensated humidity output. The thermistor temperature sensors are available with more than 16 different industry standard resistance to temperature curves offering compatibility to most if not all control systems. All thermistor sensors offer $\pm 0.2^{\circ}\text{C}$ interchangeability/accuracy and strictly conform to industry standard R/T curves. The platinum RTD's are available with 100 ohm or 1000 ohm DIN 43760 standards with $\pm 0.12\%$ accuracy at 0°C . All temperature sensors have more than 3.0 mW/ $^{\circ}\text{C}$ heat dissipation constant.

On VDC output units (humidity only), two additional field selectable options are available; dual outputs 0-5 or 0-10 VDC, and dual unregulated supply voltages 12-35 VAC or 12-40 VDC. By merely moving a switch, one can select the desired output for the specific application. As far as supply voltage is concerned, the unit automatically configures for AC or DC and no field selection is necessary. The VDC output unit is also designed to handle low impedance circuits. In fact, the unit can drive up to 1K ohm minimum. In this way, multiple controllers, indicators, or other devices can be paralleled to the output without performance degradation.

The mA output units (humidity only) function over a wide unregulated supply voltage range: 12-40 VDC without any effect on calibration or performance. The unit has reverse polarity protection built in. As a result, it is next to

impossible to damage the unit by wiring incorrectly.

By using sophisticated low dropout voltage regulators and CMOS integrated circuits, the mA output unit can drive very high output impedance. In fact, with only 12 VDC supply, the unit can drive 250 ohms. At 40 VDC, the unit is capable of handling up to a 1500 ohm load. In this way, the output loop can be tied in series to multiple controllers, indicators, and other devices without degrading the performance.

The humidity sensor is protected by an ePTFE (expanded Teflon) filter media that incorporates a proprietary process of expanding or stretching an ultra thin Teflon sheet during the manufacturing process to create less than 1.0 micron (0.000039 inch) pores or holes. The hydrophobic and oleophobic characteristics of Teflon force moisture, condensation and other contaminants to form a bubble larger than the pore size, and the surface tension of the Teflon stops the water or other contaminants from passing through the filter media, thereby protecting the sensing element. However, air with absorbed moisture can easily penetrate the filter media. The PCB electronics are coated and sealed with an acrylic conformal coating to protect against moisture, condensation and contaminants.

The HU-227 incorporates a rugged NEMA-4 (IP-65) fully gasketed, dust proof and splash proof enclosure. The enclosure has an external mounting bracket to facilitate field installation. A $\frac{1}{2}$ " (.875"/22.25 mm diameter) knock-out for conduit connection is also provided. A liquid tight cable connector is supplied if the unit is not being hard wired. Once installed, the enclosure maintains its environmental rating and protects the electronics and the sensing element from condensation, corrosive contaminants and other environmental pollutants. The enclosure also has additional features for ease of installation including unpluggable terminal block and easily accessible zero and span trimmers.

HU-227

HUMIDITY TRANSDUCER SPECIFICATIONS:

Accuracy*: $\pm 2\%$ / $\pm 3\%$ RH
Range: 0-100% RH
Hysteresis: $\pm 1\%$
Supply Voltage: 12-40 VDC
 12-35 VAC (VDC output units only)
Compensated Temp Range: -30°F to 130°F
 (-35°C to 55°C)
Load Impedance: 1.5K ohms max. at 40 VDC
 (mA output units)
 1K ohms min.
 (VDC output units)

* Includes non-linearity and non-repeatability

PLATINUM RTD SENSOR SPECIFICATIONS:

Accuracy: 0.12% at 0°C
Resistance: 100 or 1,000 ohm at 0°C
Standard: DIN 43760
Heat Dissipation: 3.0 mW/°C
R/T Characteristics: Refer to TI.700-11
 (See Temperature Sensor section)
Operating Temp Range: -30°F to 130°F
 (-35°C to 55°C)

THERMISTOR SENSOR SPECIFICATIONS:

Interchangeability: $\pm 0.2^\circ\text{C}$
Heat Dissipation: 3.0 mW/°C
R/T Characteristics: Refer to TI.700-11
 (See Temperature Sensor section)
Operating Temp Range: -30°F to 130°F
 (-35°C to 55°C)

GENERAL SPECIFICATIONS:

Environmental: 10-100%RH
Enclosure: 18 Ga C.R. Steel NEMA 4 (IP-65)
Finish: Baked on enamel - PMS2GR88B
Termination: Unpluggable screw terminal block
Wire Size: 12 Ga maximum
Weight: 1.0 lbs. (.45 kg)

CONFORMANCE & TESTING:

RoHS Compliant
EMC Testing:
 BS EN 55022:1998, BS EN 55024:1998,
 EN 61000-3-3, EN 61000-4-2,
 EN 61000-4-3, EN 61000-4-4,
 EN 61000-4-5, EN 61000-4-6,
 EN 61000-4-11

ORDERING INFORMATION: HU-227-

Accuracy	Output	Temperature Sensor
$\pm 2\%$	mA (4-20 mA 2-wire)	1 100 ohm Platinum RTD 2 1,000 ohm Nickel RTD (5000 PPM) 3 1,000 ohm Platinum RTD 4 1,000 ohm Nickel RTD (6000 PPM) 5 1,000 ohm Balco RTD 7 10,000 ohm NTC thermistor (Type III) 8 10,000 ohm NTC thermistor (Carel) 10 3,000 ohm NTC thermistor 12 10,000 ohm NTC thermistor (Type II) 13 5,000 ohm NTC thermistor 14 1,035 ohm Silicon PTC 15 100,000 ohm NTC thermistor 16 10,000 ohm NTC thermistor (Eliwell) 17 20,000 ohm NTC thermistor 18 2,252 ohm NTC thermistor 21 1,800 ohm NTC thermistor
$\pm 3\%$	VDC (0-5 VDC/0-10 VDC field selectable)	

Example: HU-227-2-mA-3: Outside Air Humidity and Temp Sensor, $\pm 2\%$ RH accuracy with 4-20 mA output and 1,000 ohm Platinum RTD.

For Resistance vs. Temperature Tables, please refer to TI.700-11.

CAUTION: Do not use in explosive/hazardous environment or with flammable/combustible media.

HU-227

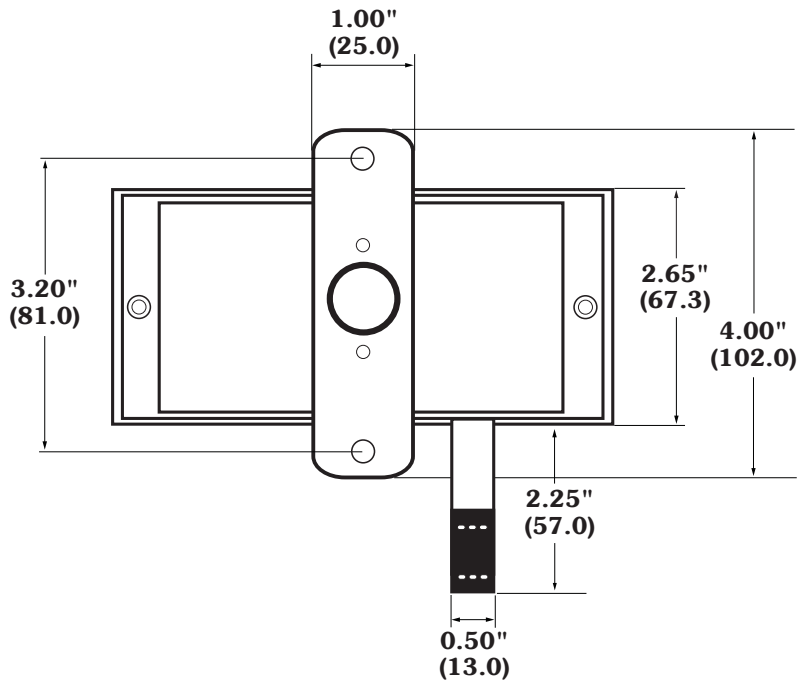
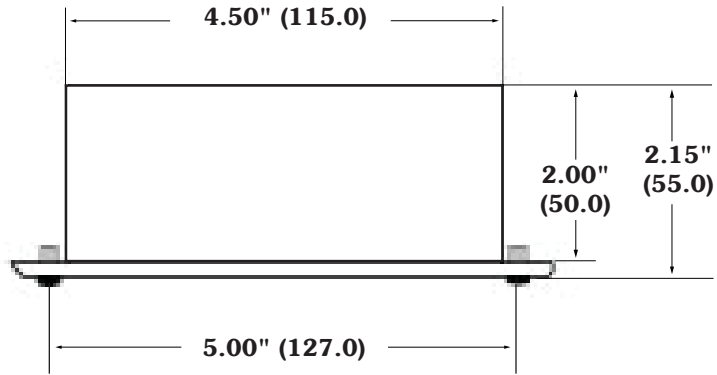

(mm)

HU-227



MAMAC Systems is the leading global manufacturer of sensors, transducers, control peripherals and web browser based IP appliances. MAMAC products are used for HVAC and environmental controls, remote monitoring, alarming, energy metering and industrial automation.

All MAMAC products are manufactured in the USA.

WARRANTY: MAMAC Systems, Inc. and its subsidiaries (hereinafter referred to as MAMAC Systems) warrants its products to be free of defects in material and workmanship for a period of five (5) years from date of shipment. If a unit is malfunctioning, it must be returned to the factory for evaluation. A return authorization number (RMA) will be issued by the customer service department and this number must be written or prominently displayed on the shipping boxes and all related documents. The defective part should be shipped freight pre-paid to the factory. Upon examination by MAMAC Systems, if the unit is found to be defective, it will be repaired or replaced at no charge to the customer. However, this warranty is void if the unit shows evidence of being tampered with, damaged during installation, misapplied, misused, or used in any other operating condition outside of the unit's published specifications.

MAMAC Systems makes no other warranties or representations of any kind whatsoever, expressed or implied, except that of title. All implied warranties including any warranty of merchantability and fitness for a particular purpose are hereby disclaimed. User is responsible to determine suitability for intended use.

LIMITATIONS OF LIABILITY: The remedies of buyer set forth herein are exclusive and the total liability of MAMAC Systems with respect to this order, whether based on contract, warranty, negligence, indemnification, strict liability or otherwise, shall not exceed the purchase price of the product upon which liability is based. **In no event shall MAMAC Systems be liable for consequential, incidental or special damages.** MAMAC Systems reserves the right to change any specifications without notice to improve performance, reliability, or function of our products.

Every precaution for accuracy has been taken in the preparation of this manual, however, MAMAC Systems neither assumes responsibility for any omissions or errors that may appear nor assumes liability for any damages that result from the use of the product in accordance with the information contained in the manual.

